

DIRETTORE D'ORCHESTRA di Luigi Leonardi

R = 2x1

Usare del cartoncino inumidito oppure della carta metallizzata ricoperta da carta velina.

Lato bianco sopra.

Applicare una striscia di nastro adesivo trasparente sulla mediana lunga, per proteggere la carta dalla rottura durante le insistenti piegature

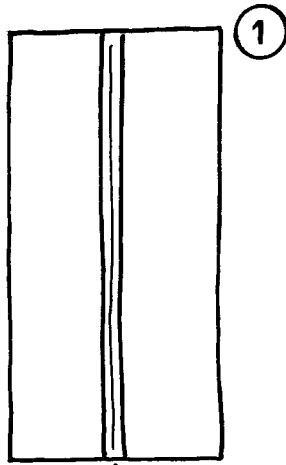

Scotch

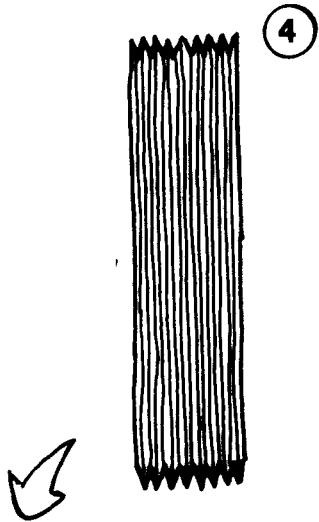
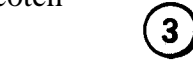
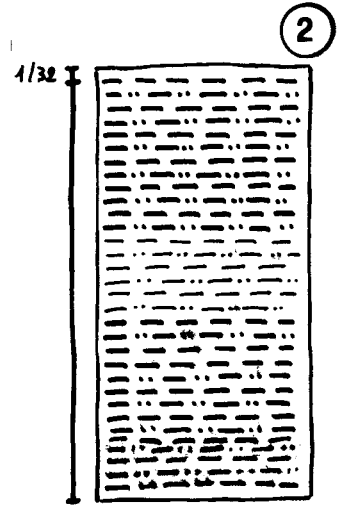

5 Piegatura ripresa dalla base dell'uomo di Neal Elias

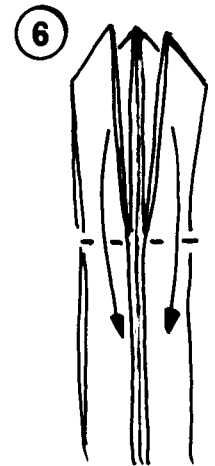
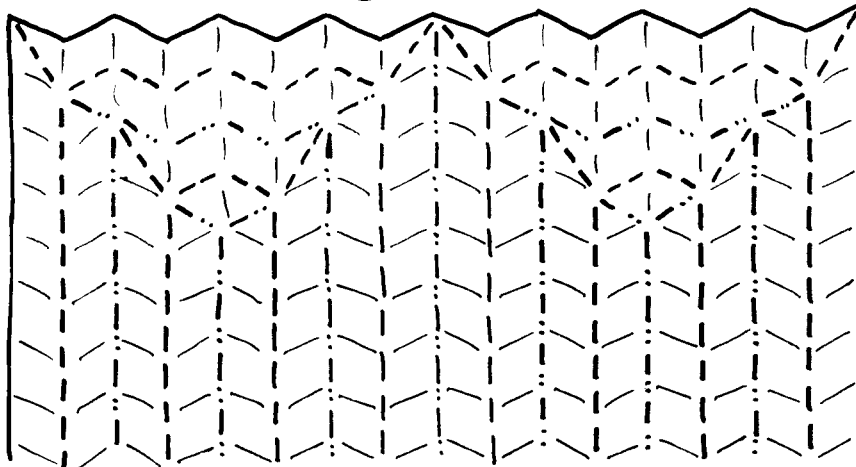

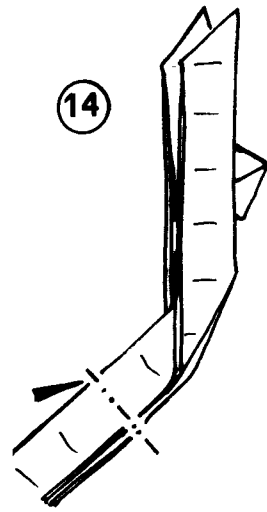
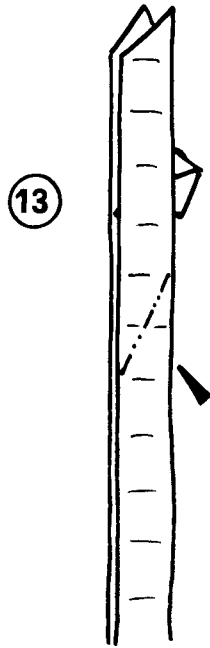
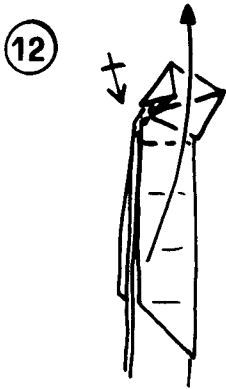
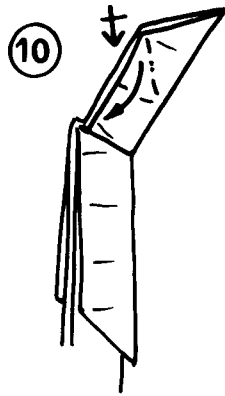
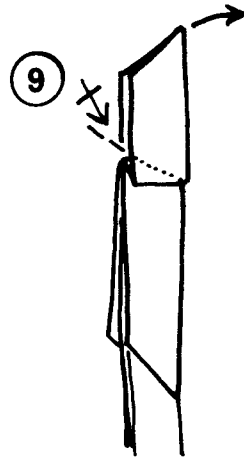
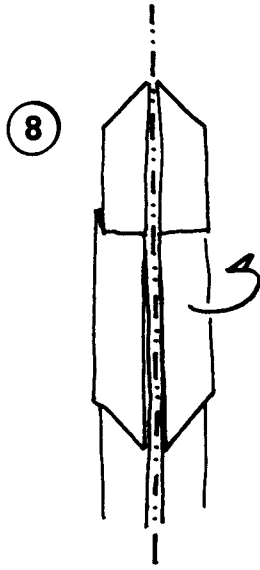
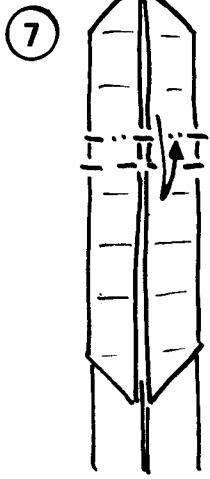

15

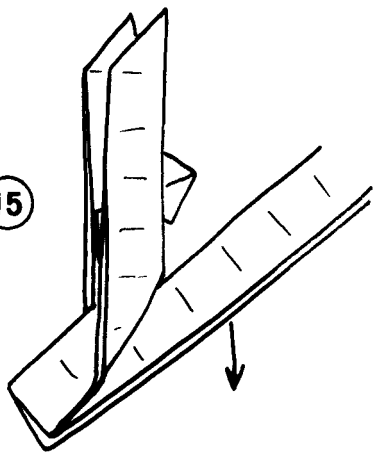

Portare delicatamente verso il basso, al fine di facilitare le successive piegature.

16

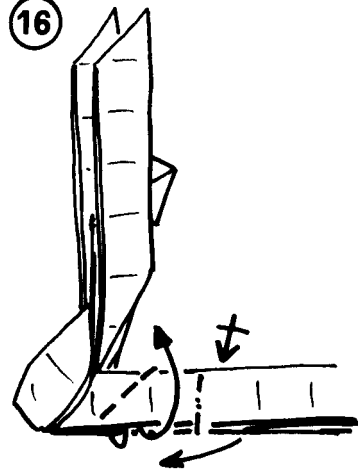

17

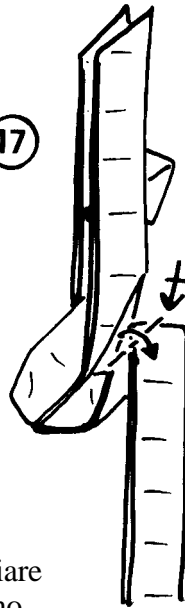

18



Agganciare all'interno.

19

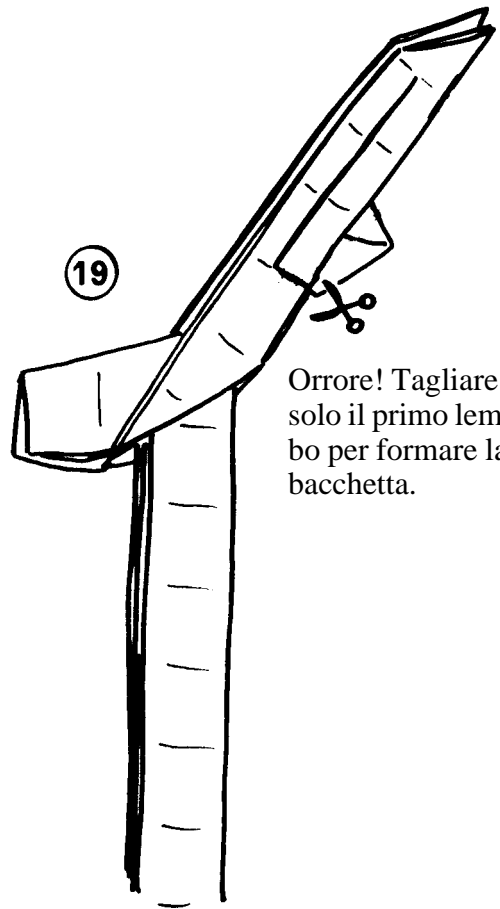

Orrore! Tagliare solo il primo lembo per formare la bacchetta.

Vista frontale

18



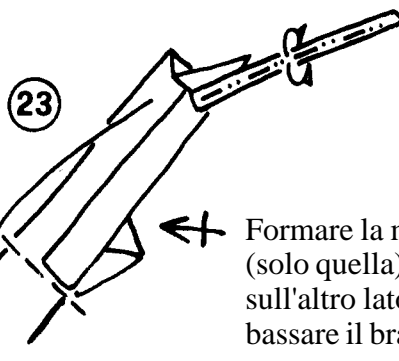
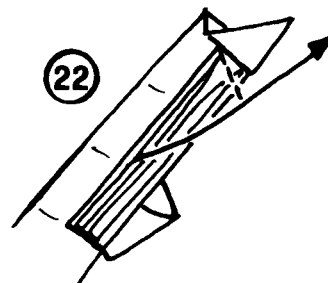
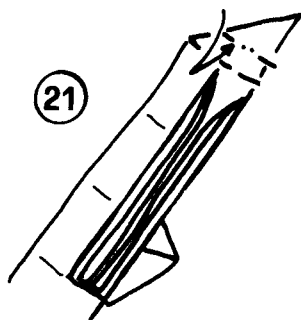
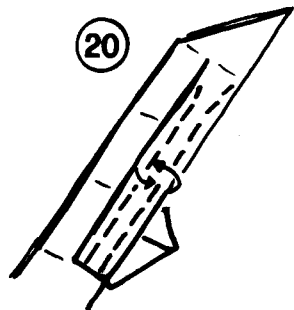

Formare la mano
(solo quella) anche
sull'altro lato e ab-
bassare il braccio.

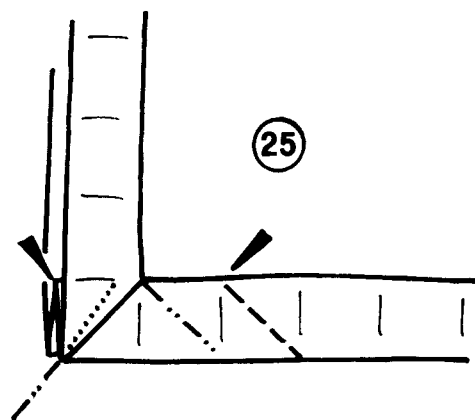
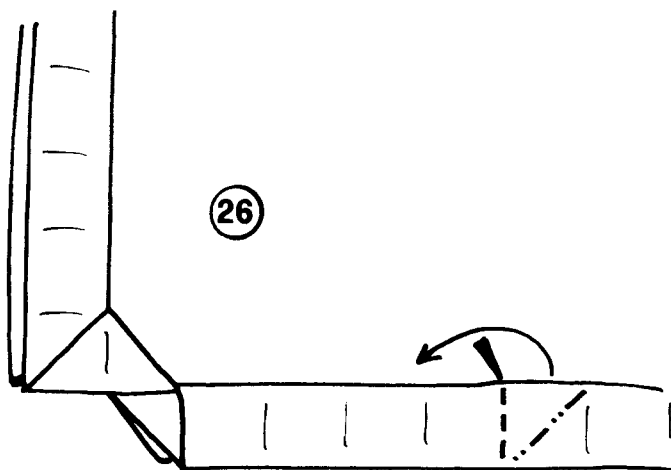
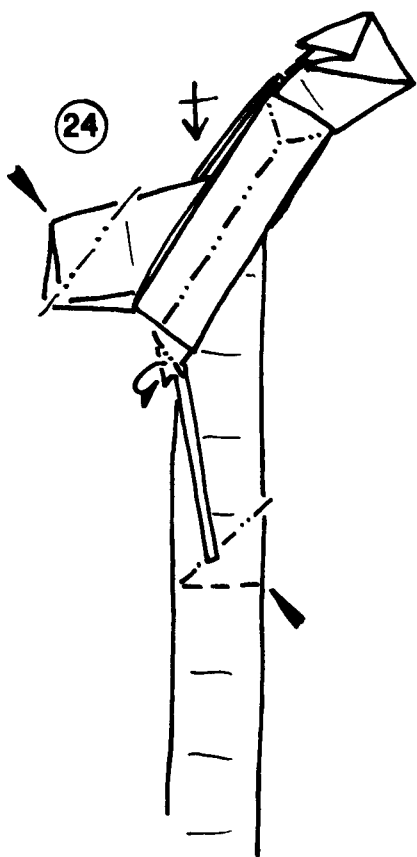

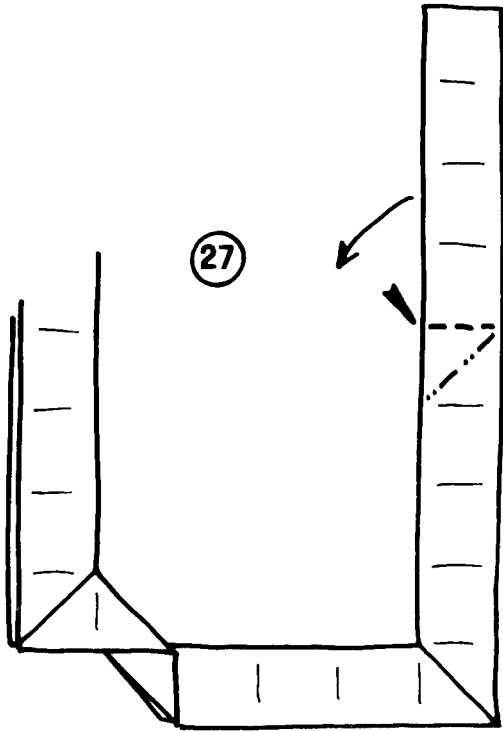

27

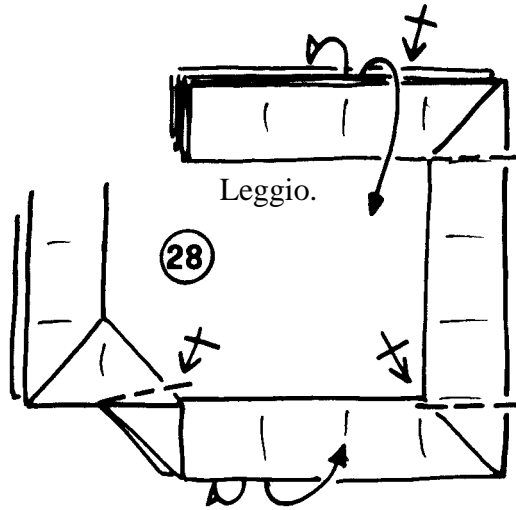

Leggio.

28

Aprire e formare il piedistallo.

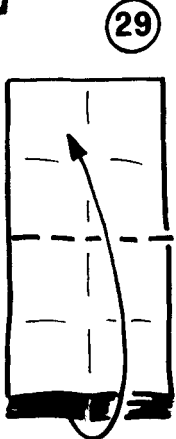

29

Leggio visto dall'alto.

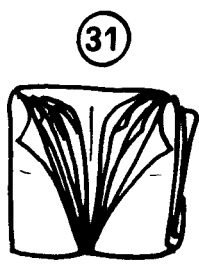

31

...così. Daranno l'impressione del leggio aperto.

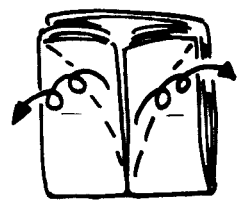

30

Arrotolare tutti i lembi verso l'esterno...

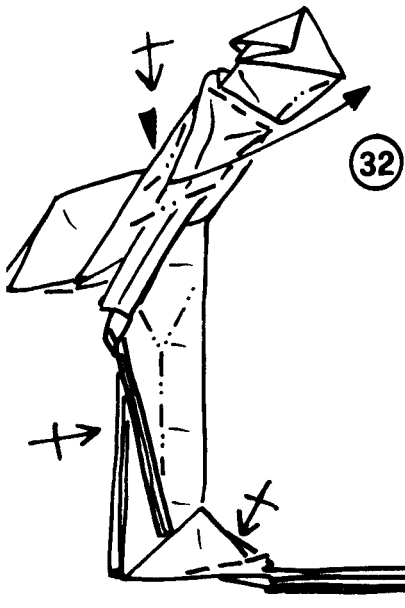

32

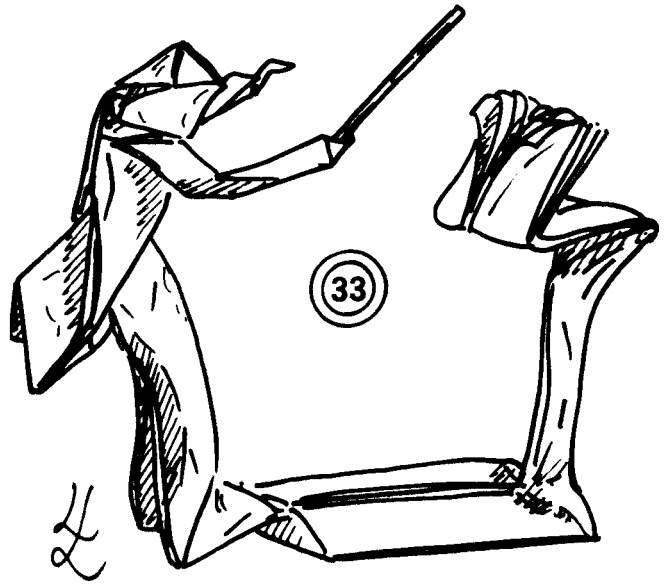

33